

## Description

RKBI is an insulated centrifugal duct fan with connections for rectangular ducts. The fan have a rigid housing of galvanised steel and are compact with high capacity. With the 50 mm high quality insulation it operates quiet and the surface of the insulation is easy to clean. RKBI is available in 16 capacities. The backward curved impeller gives a better efficiency over a very big working area than the forward curved impeller. The fan is designed to cope with high pressures i.e. long ducts with a minimum of noise. The motor is speed-controllable from 0-100% and maintenance-free, why the only service required is cleaning the impeller. Motor with impeller can be swung out for inspection and cleaning (swing-out). The RKBI fan is supplied fully-wired and ready to fit in a sealed installation unit. It is moisture-proof and approved for use in warm or cold environments. All fans are fitted with a built-in thermal protector.



## Technical data

Parameter	Value	Unit
Voltage	230	V
Phase	1	~
Frequency	50	Hz
Power	0.3	kW
Current	1.34	A
R.p.m.	15	r/s
Max. temperature of transported air	60	°C
Max. temperature of transported air when speed-controlled	60	°C
Sound pressure level at 3 m	43	dB(A)
Length	747	mm
Width	707	mm
Height	489	mm
Weight	52	kg
Enclosure class, motor	44	IP
Insulation class, motor	F	
Capacitor	8	µF
Duct connection	600x350 mm	

Diagrams

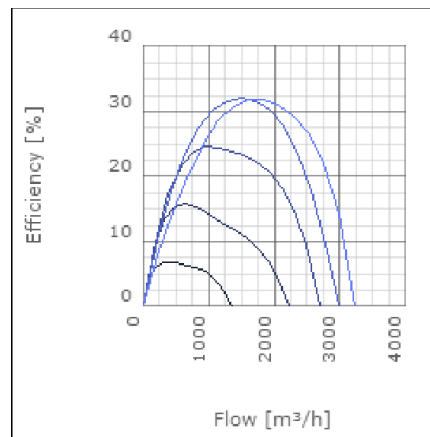
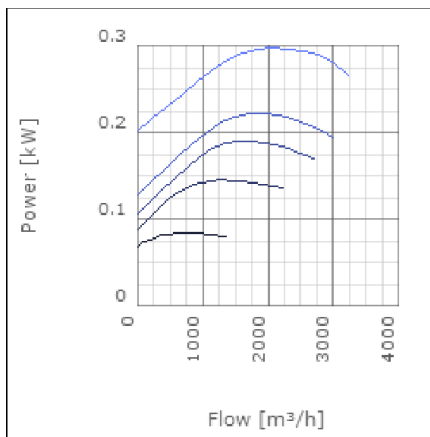
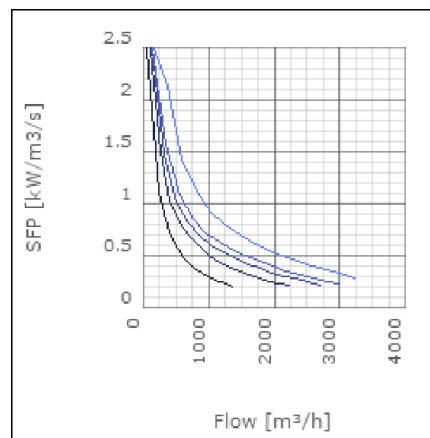
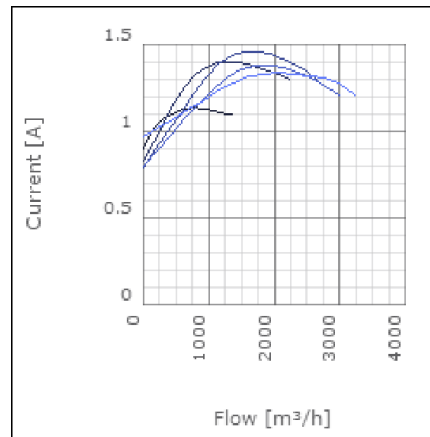
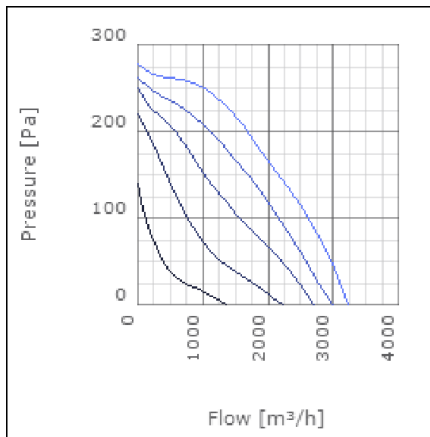

## Sound

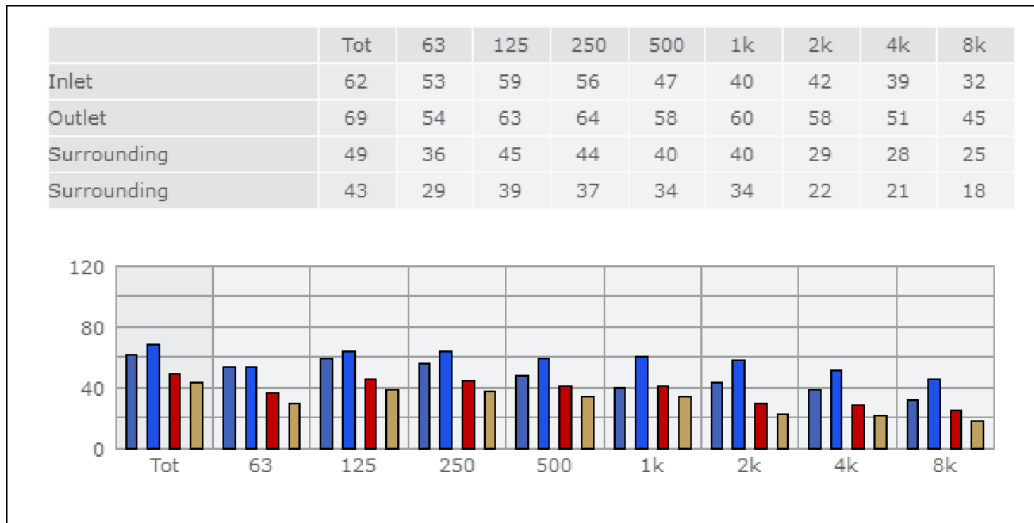

### Parameter

Distance: 3.000  
 Propagation type: Hemi-spherical  
 Equivalent absorption area: 20.00

### Checked point

Flow 1618.705m<sup>3</sup>/h  
 Static pressure 208Pa

### Working point

Flow 1619.688m<sup>3</sup>/h  
 Static Pressure 208Pa  
 Power 0.29kW  
 Speed 0r/s  
 Current 1.32A  
 Voltage 230V  
 Efficiency 31.939%  
 SFP 0kW/m<sup>3</sup>/s

## Dimensions

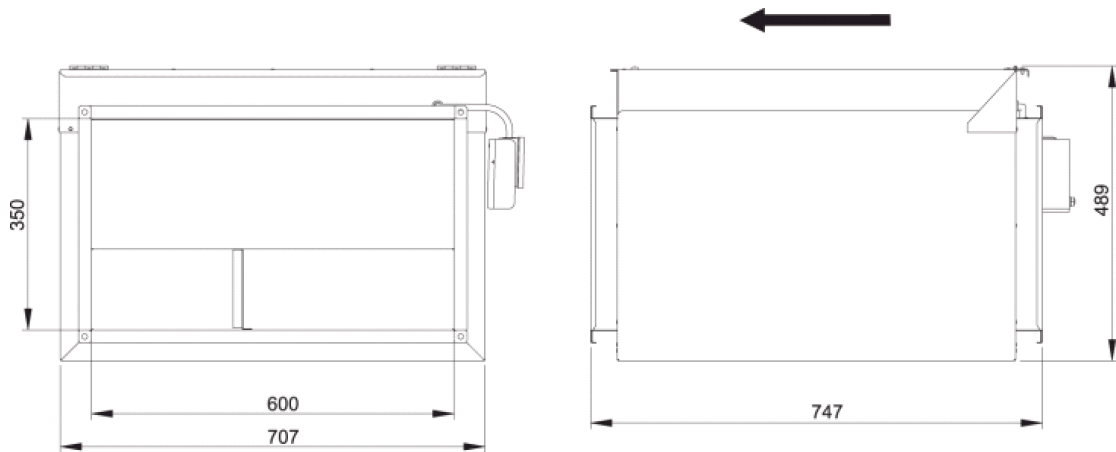

## Wiring diagram

4040005

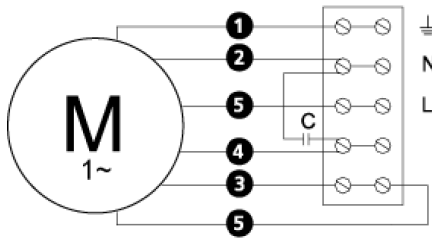

- Ⓜ = Fan Motor
- Ⓜ1 = Fan Motor
- Ⓜ2 = Fan Motor
- Ⓜ3 = Rotor Motor
- ① = Yellow/Green
- ② = Black
- ③ = Blue
- ④ = Brown
- ⑤ = White (TW)
- ⑥ = Orange
- ⑦ = Grey
- ⑧ = Red
- ⑨ = Green
- ⑩ = Violet

## Accessories

ETFV-94A  
FRE 6  
VRDE 3  
VRS 2,0  
VRTE 3

## Electrical accessories

FLR 600x350  
DS 600x350  
LDR 600x350